

Yaskawa GPD315 5HP Spindle Drive

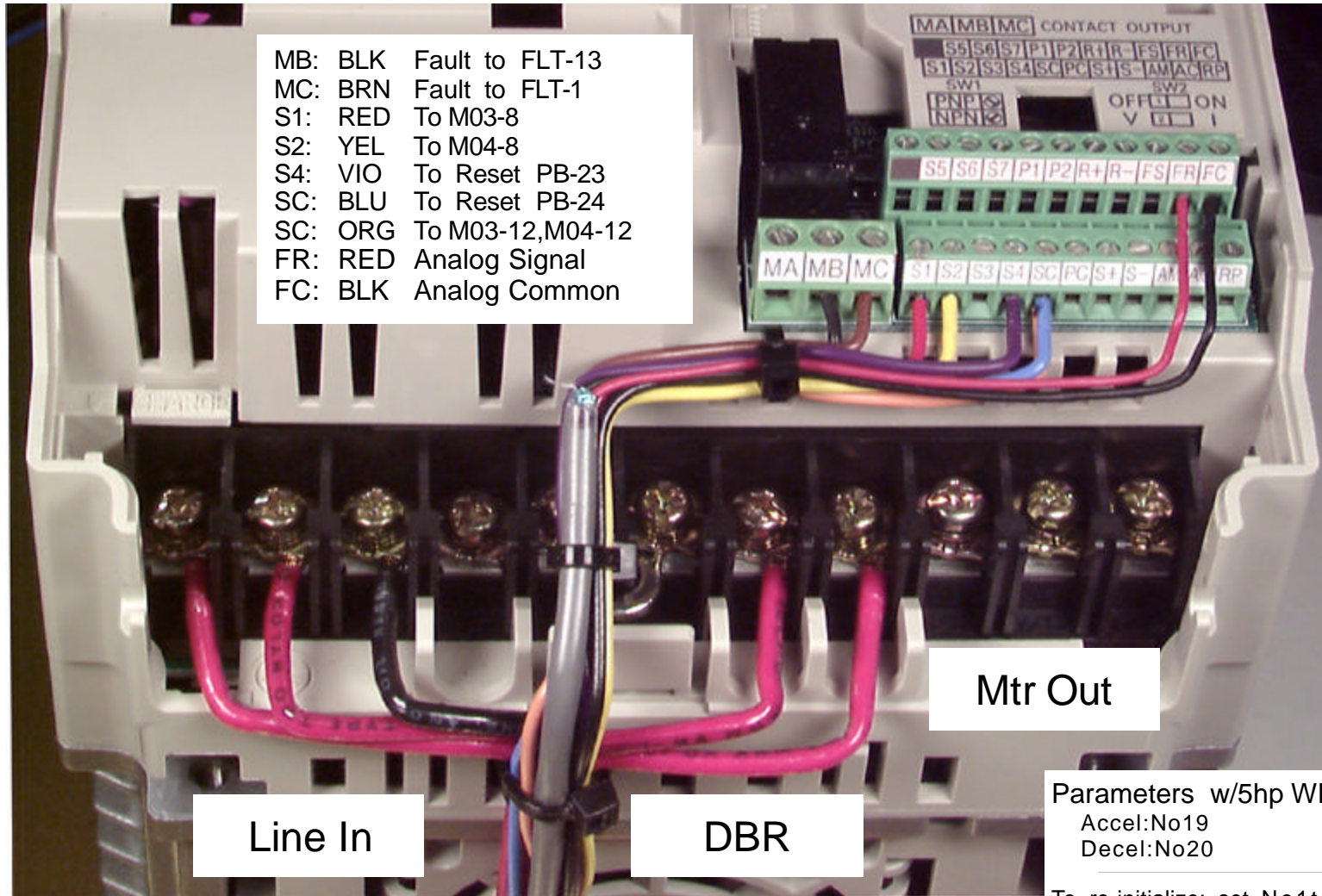

To re-initialize: set No1 to 8.
 After initialization set as follows:

001=3	011=120	036=12.9
003=1	012=230	106=1.8
004=2	019=1.0	109=250
007=0	020=1.0	110=23

NOTE: This drawing includes optional components and references not on all panels.

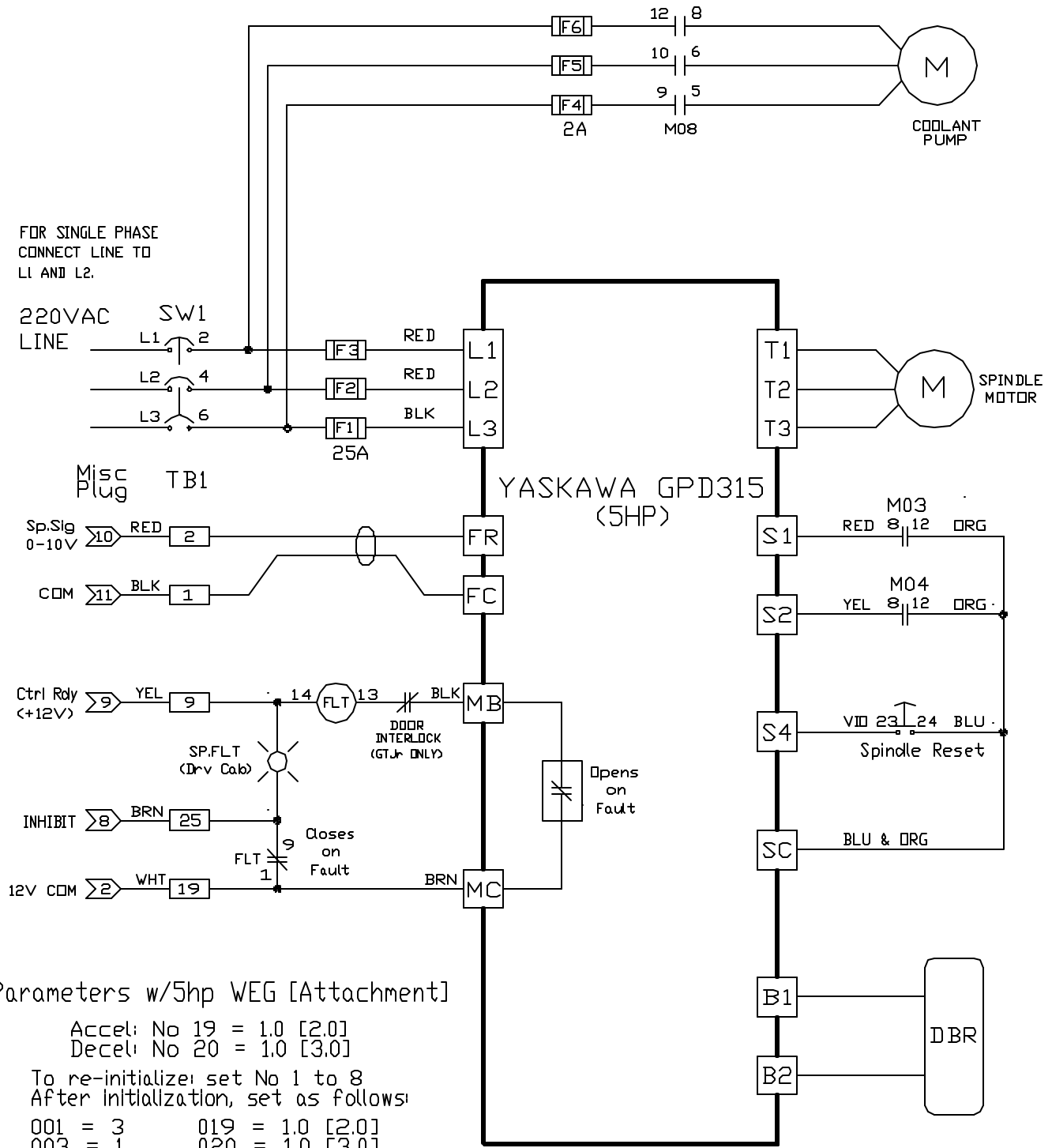

Parameters w/5hp WEG [Attachment]

Accel: No 19 = 1.0 [2.0]
Decel: No 20 = 1.0 [3.0]

To re-initialize, set No 1 to 8
After initialization, set as follows:

001 = 3	019 = 1.0 [2.0]
003 = 1	020 = 1.0 [3.0]
004 = 2	036 = 12.9
007 = 0	106 = 1.8
011 = 120	109 = 250
012 = 230	110 = 23

DBR = 30 OHMS 500W
[DPR = 62 OHMS 150W]

AC SPINDLE DRIVE (GPD 315 5HP)

OmniTurn 3/2000